

INDUSTRIAL DIESEL ENGINE

KUBOTA SUPER MINI SERIES (3-cylinder)

# D722-E4B

## RATED POWER

14.9kW@3600rpm



Photograph may show non-standard equipment.

## PERFORMANCE CURVE

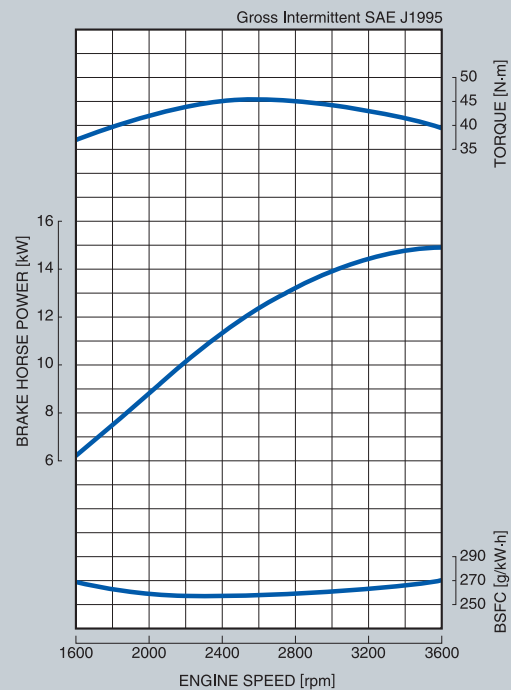

## FEATURES and BENEFITS

### Emissions

Kubota Super Mini Series, the most compact multi-cylinder liquid cooled industrial diesel engines, complies with EPA Tier 4 emissions regulations. These are the most stringent emissions regulations in the world in this class.

Kubota engine less than 19kW meets emission standards over the NRTC and also meets the NTE requirements.

### Durable Power

The Kubota Super Mini Series has been chosen as a power source for a variety of applications since it was first launched 25 years ago. It has become the benchmark in the compact diesel engine market.

The D722 engine offers a seamless transition from Tier 2 to Tier 4 by totally maintaining the same performance and physical characteristics of the previous Tier 2 engines.

Alternative fuel engines, WG752-G (Gasoline), WG752-L (LPG) and WG752-GL (Dual Fuel:Gasoline/LPG) are available with the same footprint as the D722 engine.

### Clean and Quiet Power

Kubota's original E-TVCS (Three Vortex Combustion System) has been further improved for better emissions.

# KUBOTA SUPER MINI SERIES D722-E4B

## GENERAL SPECIFICATION

Model		D722-E4B
Emission Regulation		Tier 4
Type		Vertical 4-cycle Liquid Cooled Diesel
Number of Cylinders		3
Bore	mm (in)	67 (2.64)
Stroke	mm (in)	68 (2.68)
Displacement	L (cu.in)	0.719 (43.88)
Combustion System		IDI
Intake System		Naturally Aspirated
Maximum Speed	rpm	3600
Output: Gross Intermittent ( Industrial Use )	kW	14.9
	hp	20.0
Direction of Rotation		Counterclockwise Viewed on Flywheel
Oil Pan Capacity	L (gal)	3.8 (1.00)
Starter Capacity	V-kW	12-0.8
Alternator Capacity	V-A	12-12.5
Output: Stand-by ( Generator Use )	kW	13.3
	hp	17.8
Output: Continuous ( Generator Use )	kW	12.2
	hp	16.4
Length	mm (in)	435.1 (17.13)
Width	mm (in)	404.0 (15.91)
Height (1)	mm (in)	564.1 (22.21)
Height (2)	mm (in)	219.0 (8.62)
Dry Weight	kg (lb)	63.0 (139.1)

\*Specification is subject to change without notice.  
 \*Output: Gross Intermittent SAE J1995  
 \*Output: Stand-by, Continuous ISO 3046  
 \*Dry weight is according to Kubota's standard specification.  
 When specification varies, the weight will vary accordingly.

## DIMENSIONS

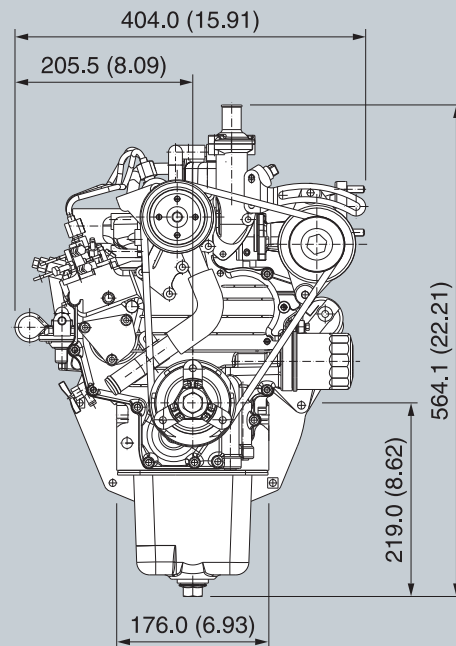
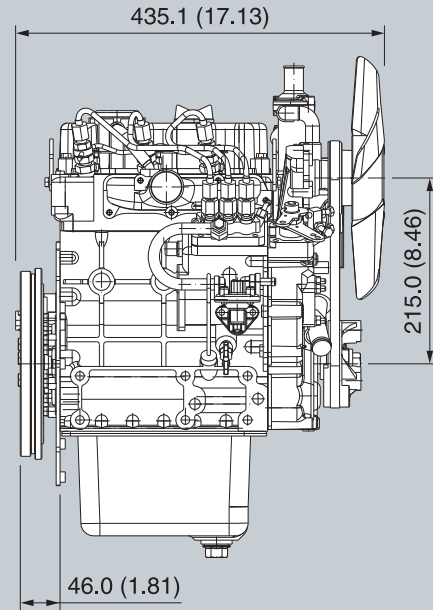

# For Earth, For Life



**KUBOTA ENGINE AMERICA**  
 505 Schelter Road Lincolnshire, IL 60069  
 Phone: 847-955-2500 Fax: 847-955-2501  
 www.kubotaengine.com

**KUBOTA CANADA, LTD**  
 5900 14th Avenue, Markham, Ontario L3S 4K4  
 Phone: 905-294-7477 Fax: 905-294-1554

7/25/2013 - KEA2044