

# ISUZU

## SPECIFICATIONS

### NPS 250 | 300 4x4

### NPS 300 4x4 Crew



NPS 300 Crew



NPS 300

AUSTRALIA'S TOP SELLING TRUCK BRAND SINCE 1989.

#### AT A GLANCE

GVM	4,500 kg (single cab) or 6,500 kg (single and crew cab)
GCM	8,000 kg (single cab) or 10,000 kg (single and crew cab)
Power	114 kW @ 2,600 rpm
Torque	419 Nm @ 1,600 - 2,600 rpm

#### ADVANCED TECHNOLOGY

Emissions: Euro V / ADR 80/03  
Meets EEV emissions standard  
Driver and passenger airbag with  
seatbelt pretensioner  
ECE-R29 compliant cab

Electric control switches for high/low  
range and 4WD engagement  
Wide 850 mm frame with parallel rails  
and rivetless top flange  
Electric mirrors  
Front stabiliser bar



THE  
**one**

**ISUZU**  
RELIABILITY IS EVERYTHING

# NPS 4x4 Single | Crew

## DRIVELINE AND CHASSIS SPECIFICATIONS

### ENGINE: SITEC SERIES III 155 (ISUZU 4HK1-TCN)

- Type:** 4 cylinder 16 valve SOHC  
**Displacement:** 5,193 cc  
**Compression ratio:** 17.5:1  
**Bore x Stroke:** 115 mm x 125 mm  
**Max power (Din-net):** 114 kW (153 HP) @ 2,600 RPM  
**(JIS Gross):** 118 kW (158 HP) @ 2,600 RPM  
**Max torque (Din-net):** 419 Nm (309 lb.ft) @ 1,600 - 2,600 RPM  
**(JIS Gross):** 434 Nm (320 lb.ft) @ 1,600 - 2,600 RPM  
**Induction system:** Electronically controlled variable nozzle turbocharger with air-to-air intercooler.  
**Fuel injection:** Direct injection high pressure common rail system.  
**Emission control system:** Cooled EGR with exhaust Diesel Particulate Diffuser (DPD). ADR 80/03 (Euro V) compliant. EEV compliant.

### CLUTCH

- Auto adjusting hydraulic control with vacuum assistance. Single plate 325 mm diameter.
- Total lining area: 966 cm<sup>2</sup>

### TRANSMISSION

#### ISUZU MYY-5T

- 5 speed manual. Syncromesh on gears 1-5.
  - PTO provision on LHS of transmission case. PTO drive from counter gear.
  - Gear ratios (: 1)
- | 1st   | 2nd   | 3rd   | 4th   | 5th   | Rev   |
|-------|-------|-------|-------|-------|-------|
| 5.315 | 3.053 | 1.655 | 1.000 | 0.721 | 5.068 |

#### TRANSFER GEARBOX:

- Part time 4WD.
- High ratio 1.00:1, Low ratio 1.842:1

### AXLES

#### Front: Isuzu FD028

- Full floating Banjo type. Birfield outer joints and manual lock front hubs. 2,800 kg capacity
- Drive ratio 5.125:1

#### Rear: Isuzu R066

- Full floating Banjo type. Four pinion limited slip differential. 6,600 kg capacity.
- Drive ratio: 5.125:1

### SUSPENSION

#### Front:

- Single stage alloy steel multi leaf springs.
- Double acting hydraulic shock absorbers. Stabiliser bar.

#### Rear:

- Multi leaf main spring, multi leaf helper spring.
- Double acting hydraulic shock absorbers.

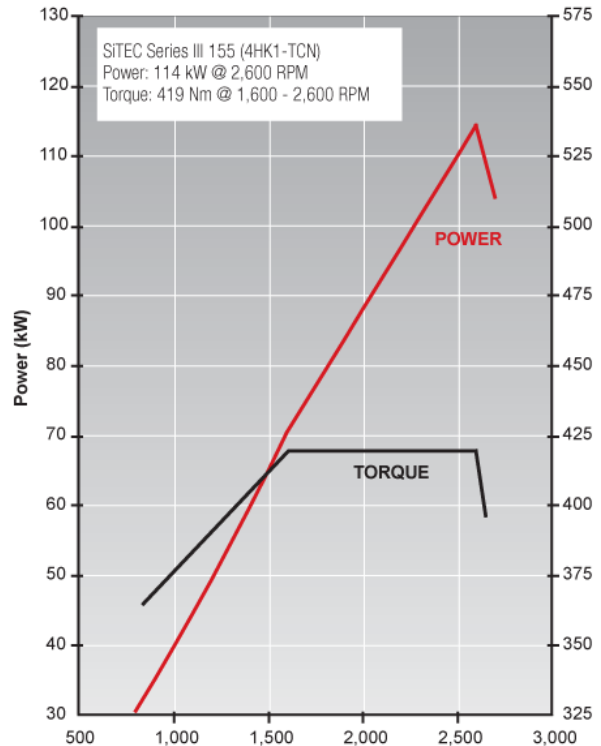

### BRAKES

- Front and rear drum brakes with dual circuit hydraulic control, vacuum assistance and load sensing proportioning valve.
- Front drum size: 320 x 75 mm
- Rear drum size: 320 x 100 mm
- 190 mm diameter drum park brake mounted on rear of transmission.
- Vacuum controlled exhaust brake.

### STEERING

- Power assisted recirculating ball steering.
- Gear ratio: 20.9:1
- Turns lock to lock: 3.7
- Maximum angle: 38° (inside wheel) / 30° (outside wheel)

### WHEELS AND TYRES

- 17.5 x 6.00 six stud steel wheels.
- 8.5R 17.5 121/120L Michelin XZT Tubeless.
- Maximum tyre rating:
  - Front axle: 2,900 kg
  - Rear axle: 5,600 kg
- 1 frame mounted spare wheel and tyre assembly.

### CHASSIS FRAME

- Cold rivetted ladder frame. SAPH440 weldable steel sidemembers. Parallel side rails and rivetless top flange.
- Frame dimensions:
  - Side rail (mm): 216 x 70 x 6.0
  - Rear frame width (mm): 850

## FUEL TANK

- Frame mounted 140L steel fuel tank.
- Lockable fuel cap.

## ELECTRICAL SYSTEM

- 24 volt electrical system.
- 80 amp alternator.
- 4.5 kW starter motor.
- 2 x 80D26L (630 CCA) batteries connected in series.

## CABIN SPECIFICATIONS AND APPOINTMENTS

### CAB EXTERIOR

- All steel construction. High tensile steel used for cab underframe.  
**Single cab:** Manual cab tilt to 45° with torsion bar assistance.
- Complies with ECE-R29 cab strength standard.
- **Single cab:** Liquid filled front and rear cab mounts.  
**Crew cab:** Rubber cab mounts.
- Heavy duty non slip entry steps.
- 90° opening internally reinforced front doors.
- Water spray suppression guards and front mudflaps.
- Laminated windscreen with shade band.
- Two speed windscreen wipers with intermittent wipe mode.
- Halogen multi-reflector headlamps incorporating turn signals. Additional door mounted side indicator lamps.
- Combination brake, turn, reverse and marker lamps, registration plate illumination lamps. Extended wiring harness. Reverse alarm.
- Roof-mounted clearance lamps.
- Heated and powered exterior main mirrors with flat glass and additional independantly adjustable convex "spot" mirrors.
- Body coloured grille.
- Body coloured impact resisting polycarbonate bumper with steel backing frame.

### CAB INTERIOR

- Contoured adjustable driver's bucket seat.
- Front passenger bench seat with 2 seat capacity.
- **Crew cab:** Engine access provided under removable driver seat base and tiltable front passenger seat.
- **Crew cab:** Rear bench seat with 4 seat capacity.
- 3-point lap sash seatbelts in all outboard seating positions. Driver and outboard front passenger seatbelts fitted with pretensioner. Centre seat lap belts.
- Driver and outboard front passenger airbag.
- Door and roof pillar entry assist grips. **Crew cab:** Full width rear grab rail with ashtray.
- Full interior trim, padded roof lining and vinyl floor covering. Driver and passenger windscreen header storage shelf.
- Tilt/Telescopic adjustable steering column, soft feel urethane steering wheel.
- Electric windows.
- Central locking with remote keyless entry and immobiliser.
- Twin cup holders. 24V cigarette lighter. Dashboard hook.
- Front door mounted storage pockets and driver's side ashtray.
- Centre console box with storage tray. Fold down storage tray behind centre seat backrest

- Fully integrated air conditioning and heater/demister with 4-speed fan and outlets for windscreen, side windows, face and floor.
- Interior lamp with On/Door/Off switch. **Single cab:** fluorescent type.  
**Crew cab:** standard type.
- 2 DIN, two speaker radio/CD multimedia unit with 4.8" LCD touch screen and Bluetooth. Provision for SD card, USB and 3.5 mm plug inputs.
- DIN sized compartment for storage or for CB radio installation.

### DRIVER CONTROLS

- Key-operated engine start/stop and steering lock. Engine idle speed control.
- DPD regeneration.
- High/low range and 4WD engage switches.
- **Left side combination stalk:** Windscreen wipers, washers and exhaust brake.
- **Right side combination stalk:** Turn signals and headlamps.

### INSTRUMENTATION

- Electronically driven speedometer and tachometer. Digital odometer with integrated dual tripmeter. Engine coolant temperature and fuel level gauges.
- **Warning lamps:** Check engine, oil pressure, SRS airbag, alternator charge, service brakes, park brake, seatbelt unfastened, low fuel level.
- **Indicator lamps:** Warm up system, high beam, DPD status, exhaust brake, low range engaged, 4WD engaged, turn signals.

### OPTIONS AND GENUINE ACCESSORIES

Include the following (extra cost, request a brochure and further details from your Isuzu dealer):

- Isuzu satellite navigation - integrates with multimedia unit.
- Up to three audio/visual reversing cameras - integrates with multimedia unit.
- Airbag compatible bullbar.
- 3,500 kg rated towbar.
- Air deflector.



**ISUZU**  
RELIABILITY IS EVERYTHING

### WEIGHTS (kg)

Models	Ratings*		Loading Limit* (at ground)		Cab Chassis Mass #		
	GVM	GCM	Front	Rear	Front	Rear	Total
NPS 250 / 300 4x4	4,500 / 6,500	8,000 / 10,000	2,800	5,600	1,870	970	2,840
NPS 300 4x4 Crew	6,500	10,000	2,800	5,600	2,040	1,030	3,070

Maximum Gross Trailer Mass: 750 kg (unbraked), 3,500 kg (braked) \* Vehicle ratings and front/rear weight limits are subject to government regulatory requirements and weight distribution analysis. Consult your Isuzu dealer to select the correct vehicle for your specific application. # Cab chassis only as supplied and including 10 litres of fuel.

### DIMENSIONS (mm)

Models	WB	OAL	FOH	ROH	EA	CE	RT	ORT	CH	FFA (unladen)	RFA (unladen)	RFH (unladen)	KERB TO KERB
NPS 250 / 300 4x4	3,395	6,015	1,110	1,510	2,710	4,332	1,650	2,120	2,470	865	950	975	13.6
NPS 300 4x4 Crew	3,395	6,015	1,110	1,510	1,730	3,331	1,650	2,120	2,470	860	950	980	13.6

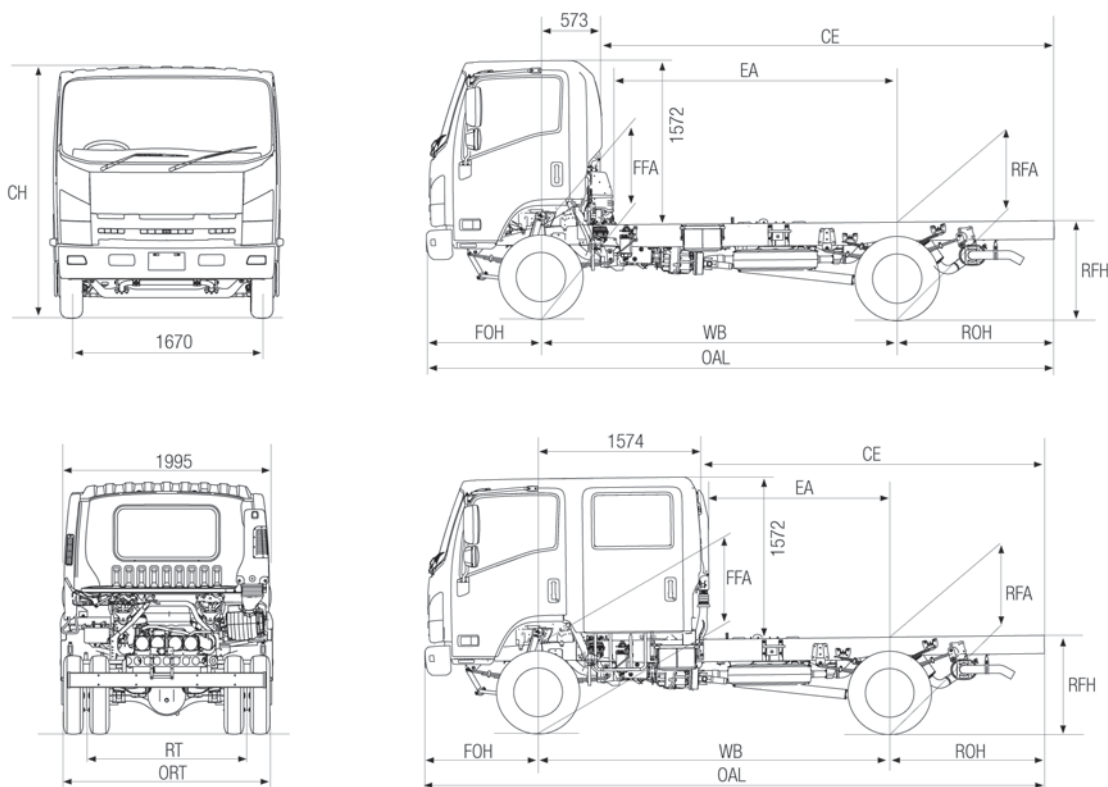

### PERFORMANCE (calculated - typical paved road)

		Geared Speed*	Low Speed Gradeability	Engine Speed
		(top gear at peak power engine RPM)	(lowest forward gear assuming no wheel slip)	(top gear at 100km/h)
NPS 250/300 4x4	NPS 250 single cab 4x4 at 4,500 kg GVM	104 km/h @ 2,600 RPM	> 100%	2,505 RPM
NPS 300 4x4 Crew	NPS 300 single and crew cab 4x4 at 6,500 kg GVM	104 km/h @ 2,600 RPM	74%	2,505 RPM

\*Maximum speed achievable depends on vehicle frontal area as well as other factors. Consult your Isuzu dealer for more detailed information.

### ISUZU WARRANTIES

STANDARD <sup>1</sup>		
New Vehicle	3 years • 100,000km • 2,000 hours	
Cab Perforation Corrosion	3 years • Unlimited km	
EXTENDED <sup>2</sup>		
4 years • 200,000 km	5 years • 250,000 km	6 years • 300,000 km
Isuzu Assist - 24 hour roadside assistance (3 years, unlimited km's)*		

### ORDER CODES

Model	Code
NPS 250 / 300	NH-NPSCB-B11 (C7G)
NPS 300 Crew	NH-NPSGB-B12

<sup>1</sup> Subject to the conditions outlined in the IAL New Vehicle Warranty, the Isuzu NPS models carry a standard factory warranty which covers the owner: (i) for the entire vehicle, for the first 36 months or 100,000 km or 2,000 hrs (whichever comes first), (ii) against cab perforation corrosion, for 36 months and unlimited kilometres. <sup>2</sup> Extended Warranty as illustrated is available by purchase to cover the owner against the failure of original components, but may exclude some components and expendable items such as oil, filters, etc. Please consult with your Isuzu Dealer for full details obtained from a dedicated brochure available to customers. \*Valid for three years from the date of new vehicle purchases.

ISUZU AUSTRALIA LIMITED ABN 97 006 962 572 ("IAL"). The information in this brochure was correct at time of printing, but all measurements, specifications and equipment are subject to change without notice. Some equipment may have been changed and/or is available at extra cost. IAL may make changes at any time without notice, in prices, colours, materials, equipment and models. IAL makes all reasonable attempts to ensure the availability of all vehicles and equipment. The information in this brochure is general in nature. Your Isuzu dealer can confirm all measurements, specifications and vehicle / equipment availability upon request.

TIC: Isuzu is a member of the Truck Industry Council - Safer Greener Essential.  
September 2012. ARK0602



**ISUZU**  
RELIABILITY IS EVERYTHING